

Dante® Network Intercom

BEATRICE D8+
Eight Channel Desktop Intercom

Highlights

Dante® and
AES67 Compliant

Simple To Use

Intelligible
Loudspeaker

48kHz Crystal
Clear Digital Audio

Mains/
PoE Powered

Low Noise
Microphone Amp

Overview

The Glensound BEATRICE D8+ is a versatile and fully featured, 8 channel desktop intercom with crystal clear audio designed for broadcast, theatre and professional audio applications.

It is part of our Beatrice intercom system that utilises the reliable and proven Dante network audio transmission protocol to allow real time distribution of uncompressed audio across standard networks. It is also AES67 compliant. As such the BEATRICE D8+ is fully compatible with other manufacturers' equipment using the Dante and/ or AES67 protocols.

This desktop intercom was designed to be very easy to use for the operator and simple to set up for the technician. It includes all the basic functionality required for small intercom systems and none of the overly complex installation requirements normally associated with large systems.



- 8 Channels Of Intercom**

One single user connected to the unit can listen to and communicate with 8 separate locations on the network. Depending upon how the Dante network has been routed the incoming audio circuits and outgoing circuits can be different locations.
- 2 Racks make 16 Channels**

Two Beatrice D8+ units can be joined together by just a pair of digital S/PDIF cables making a fully featured 16 channel intercom unit, with groups, mics, speakers and other resources shared between the 2 units.
- Dante Routing & Partyline**

Audio routing to/ from other devices is setup using Dante controller which allows for point to multipoint routing on outgoing circuits (but only 1 single incoming circuit for each of the 8 channels). Therefore we've included an inbuilt fixed ratio 14 input 19 output mixer matrix with inputs and outputs connected directly to the Dante / AES67 network which allows for setting up partyline and complex group circuits.
- Onboard Mic & External Mic Input**

A good quality, clear sounding microphone amplifier designed for communication purposes is fitted which also has the benefit of a compressor/ limiter circuit to help keep levels and intelligibility consistent even when the operator gets overly excited. This microphone amp has two microphone sources, either the inbuilt front panel mounted electret capsule which provides good voice intelligibility from normal working distances, or a balanced XLR input for connecting external gooseneck microphones. Twelve Volt Phantom power is also available and can be turned on/ off as required via an internal link.
- High Output Intelligible Loudspeaker**

What's the point of an intercom unit if the onboard speaker is so cheap that you can't understand what is being said to you? We tried hundreds of different drive units before settling on the one used in the Beatrice D8+. We chose it because it had a much cleaner sound and better frequency response for vocals than any other speaker on the market that we tested.

BEATRICE D8+

Eight Channel Desktop Intercom

Features



- Mains or PoE Powered**

An inbuilt wide range switch mode mains power supply is fitted for powering the Beatrice D8+. It is terminated with a standard IEC plug, making it easy to plug in wherever you are in the World.

The unit can also be powered via the Ethernet cable by standard PoE (Power over Ethernet) on either of the copper Ethernet ports. The PoE power can be supplied by an external PoE switch or a midspan power injector.
- Redundant Twin Copper & Twin Fibre Ethernet Interface**

When ultra reliable communications is needed for the utmost important jobs, glitch free redundant network circuits can be set up using the primary and secondary Dante network ports.

There are 2 copper Ethernet ports on Neutrik Ethercons and also 2 fibre Ethernet ports presented as SFP slots (SFP modules not included). Redundant networks can be set up across any of these ports. These ports can also be setup as a network switch.
- GPIO**

There are nine solid state relay outputs. One of these outputs is triggered when any speak key is on (useful for dimming external loudspeakers or red light controls). The other eight are triggered individually when their associated channel receives a call.

In total there are 12 loop closure inputs. 10 of these control the talk keys (the 8 channels, talk to group & talk to all) and the other 2 provide internal & external LS cuts.

Intercom & Talkback





Microphone Level Meter

An eight LED front panel multipurpose indicator is used to indicate the outgoing microphone level.

- Channel Input and Output Gain Controls**

For maximum flexibility gain can be applied to incoming audio signals and outgoing signals separately. A row of LEDs indicate the current gain setting when a channel's input or output is being adjusted.
- Monitor Selection**

Each channel has an illuminated audio monitor switch. This allows the channels' incoming audio circuit to be routed to the headphones/ loudspeakers. Using these switches makes it easy for an operator to just monitor the desired incoming audio channels.
- Call Function**

A simple call function is inbuilt allowing the operator of one unit to call/alert other users that they want to communicate with. A simple double tap of the speak key initiates a calling signal sent to the other party. The audio presence indicator flashes to indicate that you have been called. As well as the flashing LED at the receiving end of the call an audible 'beep' can be set to alert the user that an incoming call has been placed to them.
- Presence Indication**

A front panel illuminated red switch is used to indicate the presence of incoming audio on that channel. When audio is detected on the channel the switches internal red LED is illuminated, the red LED then stays on for a short period after the incoming audio stops to help the operator identify who has been talking to them.



Speaker Output

As well as the front panel internal loudspeaker a balanced analogue output is provided for connecting to an external powered loudspeaker.

- 4-Wire Connectivity**

Two traditional analogue 4-wire circuits can be connected to two of the D8+'s intercom channels by utilising the versatile analogue inputs and outputs.



- Local Input and Output Circuits**

For increased versatility there are 2 local balanced analogue audio inputs and 2 local balanced analogue outputs. The inputs have input gain controls and presence detectors on them (just like an intercom's channel input) and are routed directly to two output channel on the Dante/ AES67 network. The outputs are fed directly from two input channels from the Dante/ AES67 network.
- Mixer Matrix For Partyline**

For setting up more complex groups and partyline circuits that could not be achieved via Dante controller or your AES67 router, an inbuilt fixed ratio mixer is supplied. It has 14 audio inputs direct from the network and 19 mix outputs to the network. 5 of the mixers have inbuilt automatic audio ducking circuits.

MIX OUTPUT		SUM OFF	NOTES
<i>Dante Output Channel No:</i>	<i>Default Name in Dante Controller:</i>	<i>Dante Receiver Channel Nos:</i>	
14	"Sum of 19 to 32"	19 to 32	
15	"Sum of 19 to 25"	19 to 25	
16	"Sum of 26 to 32"	26 to 32	
17	"Sum of 19 to 21"	19 to 21	
18	"Sum of 22 to 24"	22 to 24	
19	"Sum of 25 to 27"	25 to 27	
20	"Sum of 28 to 30"	28 to 30	
21	"Sum of 19 & 20"	19 and 20	
22	"Sum of 21 & 22"	21 and 22	
23	"Sum of 23 & 24"	23 and 24	
24	"Sum of 25 & 26"	25 and 26	
25	"Sum of 27 & 28"	27 and 28	
26	"Sum of 29 & 30"	29 and 30	
27	"Sum of 31 & 32"	31 and 32	
28	"Sum of 19 & 20 Dim"	19 and 20	Note Mix in 19 dimmed when signal present on Mix in 20
29	"Sum of 21 & 22 Dim"	21 and 22	Note Mix in 21 dimmed when signal present on Mix in 22
30	"Sum of 23 & 24 Dim"	23 and 24	Note Mix in 23 dimmed when signal present on Mix in 24
31	"Sum of 25 & 26 Dim"	25 and 26	Note Mix in 25 dimmed when signal present on Mix in 26
32	"Sum of 27 & 28 Dim"	27 and 28	Note Mix in 27 dimmed when signal present on Mix in 28

Simplified Block Diagram

The audio block diagram below shows an analogue representation of the digital audio routes within the Beatrice D8+ excluding the fixed ratio mixer.

Block Diagram

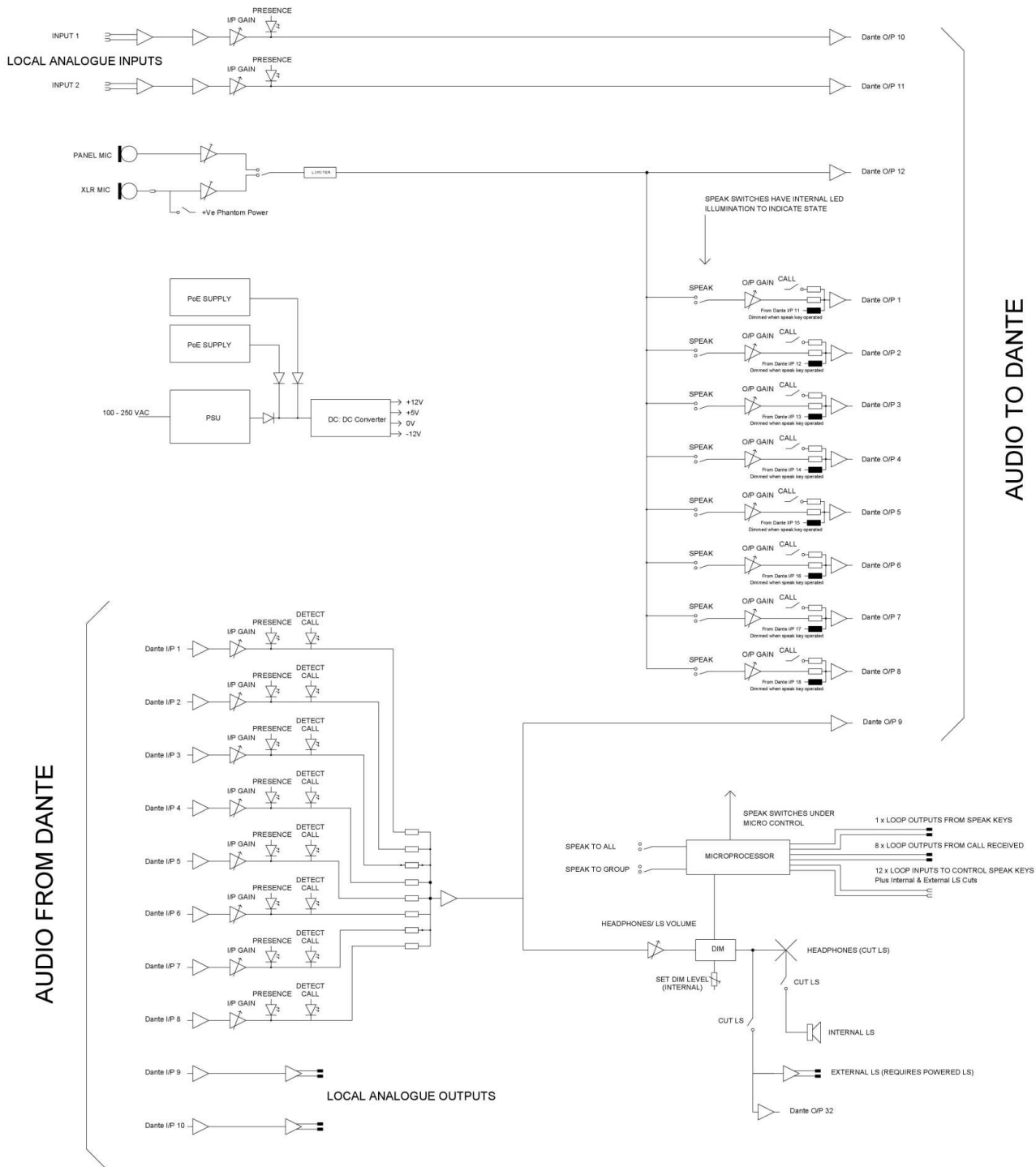

Intercom & Talkback

AUDIO TO DANTE



BEATRICE D8+

Eight Channel Desktop Intercom

Specification

NETWORK/ Dante

Physical Interface

2 off RJ45 Neutrik Ethercon
2 off SFP slots

Audio Sample Frequency

48kS/s

Transfer Rate

1000 Mbps

Dante Chipset

Brooklyn II

Note: suitable for acting as master clock for a network incorporating many Ultimo chipsets

AES67 Compliant

AES67 compliant

AUDIO

Mic Gain Range

61 to 21dB

Phantom Power

12 Volts (set via internal link)

Equivalent Input Noise

-126dB (20-20KHz RMS A Weighted 150 Ohms)

Headphone Impedance

32 - 1000 Ohms

Max Headphone Output Level

+14dB into 600 Ohms

Headphone Connector

6.35mm (1/4") TRS socket

Band Pass Filter

50Hz to 15kHz

POWER

Mains Voltage

100 - 240 VAC +/-10%

Mains Frequency

50 to 60 Hz

Power over Ethernet (PoE)

48V

Consumption

15 Watts

Redundancy

Mains & PoE supplies are dioded together for glitch free redundancy

Call Circuit

Inband Calling Frequency

20kHz

Amplitude

-20dBFS

Duration Of Signal

2 seconds

Compatibility

All Glensound Beatrice units & Studio Technologies

GPIO

GPO

Solid State Relays. Wired N'O and N'C

GPI

Logic level pull down to ground to operate

PHYSICAL

Mechanics

All aluminium with laser etched panels and light textured black powder coated sides

Size

348 x 170 x 100mm (W x D x H)

Weight

1.8Kg 3.5lb

Shipping Weight

3.5Kg

Shipping Size

62 x 42 x 17 cms

Shipping Carton

Rugged export quality cardboard

ENVIRONMENTAL

Operating Temperature

0 to +50 °C (32° to 122°F)

Storage Temperature

-20 to +70 °C (-4° to 158°F)

Relative Humidity

0 to 95% non-condensing

INCLUDED ITEMS

Handbook

Physical A5 (download also available)

RJ45 Network Cable

2 metre Cat5 RJ45plug /RJ45plug cable

Intercom & Talkback



Glensound
Keeps Working

The name **Beatrice** was chosen for our intercom range as she was the love of Dante Alighieri:

'Dante had fallen in love with another, Beatrice Portinari (known as Bice), whom he first met when he was only nine.' Source Wikipedia.

We hope that you will also fall in love with Beatrice.

E & OE